

Instructions for use

WASHING MACHINE

GB

English,1

WIB 101

Contents

Installation, 2-3-4-5

Unpacking and levelling
Electric and water connections
The first wash cycle
Technical details

Washing machine description, 6-7

Control panel
Leds

Starting and Programmes, 8

Briefly: how to start a programme
Programme table

Personalisations, 9

Setting the temperature
Functions

Detergents and laundry, 10

Detergent dispenser
Preparing your laundry
Special items

Precautions and advice, 11

General safety
Disposal
Saving energy and respecting the environment

Care and maintenance, 12

Cutting off the water or electricity supply
Cleaning your appliance
Cleaning the detergent dispenser
Caring for your appliance door and drum
Cleaning the pump
Checking the water inlet hose

Troubleshooting, 13

Service and Guarantee, 14-15-16

GB

Installation

GB

! Keep this instruction manual in a safe place for future reference. Should the appliance be sold, transferred or moved, make sure the instruction manual accompanies the washing machine to inform the new owner as to its operation and features.

! Read these instructions carefully: they contain vital information on installation, use and safety.

Unpacking and levelling

Unpacking

1. Unpack the washing machine.
2. Check whether the washing machine has been damaged during transport. If this is the case, do not install it and contact your retailer.

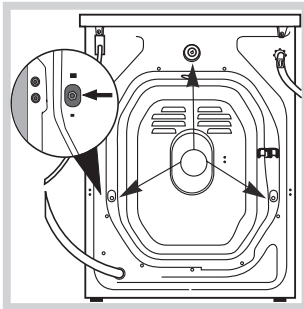

3. Remove the 3 protective screws and the rubber bush with the respective spacer, situated on the rear of the appliance (see also the installation leaflet). **NB:** The plastic spacers may fall down inside the machine once the bolt

has been removed, and will not interfere with the operation of the machine.

4. Seal the gaps using the plastic plugs provided.
5. Keep all the parts: you will need them again if the washing machine needs to be moved to another location.

! Packaging materials are not children's toys.

Levelling

Your machine may make a considerable amount of noise if the two front feet have not been adjusted correctly.

1. Install the washing machine on a flat sturdy floor, without resting it up against walls, furniture cabinets or other.

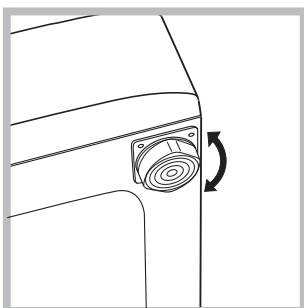

2. If the floor is not perfectly level, compensate for any unevenness by tightening or loosening the adjustable front feet (see figure); the angle of inclination, measured according to the worktop, must not exceed 2°.

Levelling your appliance correctly will provide it with stability and avoid any vibrations, noise and shifting during operation. If it is placed on a fitted or loose carpet, adjust the feet in such a way as to allow enough room for ventilation beneath the washing machine.

Electric and water connections

Connecting the water inlet hose

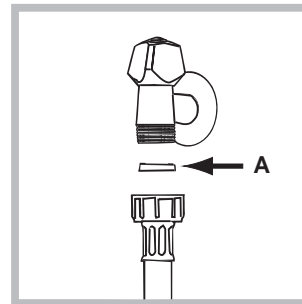

1. Insert seal A into the end of the inlet hose and screw the latter onto a cold water tap with a 3/4 gas threaded mouth (see figure). Before making the connection, allow the water to run freely until it is perfectly clear.

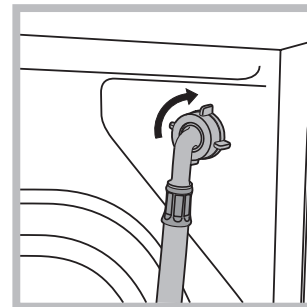

2. Connect the other end of the water inlet hose to the washing machine, screwing it onto the appliance's cold water inlet, situated on the top right-hand side on the rear of the appliance (see figure).

3. Make sure there are no kinks or bends in the hose.

! The water pressure at the tap must be within the values indicated in the Technical details table (on the next page).

! If the water inlet hose is not long enough, contact a specialist store or an authorised serviceman.

! Ensure that the supply taps are allowing water through. Old taps may seize in the closed position and thus prevent water reaching the machine.

Connecting the drain hose

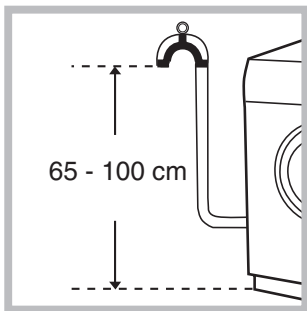

Connect the drain hose, without bending it, to a draining duct or a wall drain situated between 65 and 100 cm from the floor;

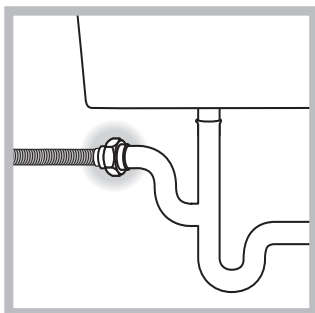

The drain hose may be connected to an under-sink trap. Before connecting the drain hose from the machine ensure that any blanks or removable ends have been taken off the spigot.

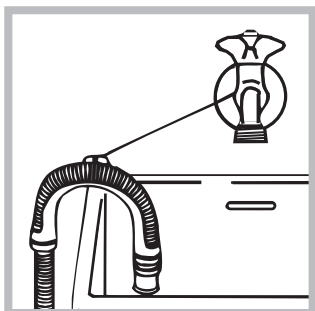

If it is placed over the edge of a basin or sink be sure the free end of the hose should not be underwater.

! We advise against the use of hose extensions; in case of absolute need, the extension must have the same diameter as the original hose and must not exceed 150 cm in length.

Ensure that if the drain hose is pushed into a standpipe, that the end does not go down more than 15cms (6 inches). If the hose is pushed down too far, this may cause the machine to self-siphon i.e. continuously empty as it is filling.

Electric connection

Before plugging the appliance into the mains socket, make sure that:

- the socket is earthed and in compliance with the applicable law;
- the socket is able to sustain the appliance's maximum power load indicated in the Technical details table (see page 5);

- the supply voltage is included within the values indicated on the Technical details table (see page 5);

- the socket is compatible with the washing machine's plug. If this is not the case, replace the socket or the plug.

Your appliance is now supplied with a 13 amp fused plug it can be plugged into a 13 amp socket for immediate use. Before using the appliance please read the instructions below.

WARNING - THIS APPLIANCE MUST BE EARTHED. THE FOLLOWING OPERATIONS SHOULD BE CARRIED OUT BY A QUALIFIED ELECTRICIAN.

Replacing the fuse:

When replacing a faulty fuse, a 13 amp ASTA approved fuse to BS 1362 should always be used, and the fuse cover re-fitted. If the fuse cover is lost, the plug must not be used until a replacement is obtained.

Replacement fuse covers:

If a replacement fuse cover is fitted, it must be of the correct colour as indicated by the coloured marking or the colour that is embossed in words on the base of the plug. Replacements can be obtained directly from your nearest Service Depot.

Removing the plug:

If your appliance has a non-rewireable moulded plug and you should wish to re-route the mains cable through partitions, units etc., please ensure that either:

the plug is replaced by a fused 13 ampere re-wearable plug bearing the BSI mark of approval. or:

the mains cable is wired directly into a 13 amp cable outlet, controlled by a switch, (in compliance with BS 5733) which is accessible without moving the appliance.

Disposing of the plug:

Ensure that before disposing of the plug itself, you make the pins unusable so that it cannot be accidentally inserted into a socket.

Instructions for connecting cable to an alternative plug: Important: the wires in the mains lead are coloured in accordance with the following code:

Green & Yellow	Earth
Blue	Neutral
Brown	Live

As the colours of the wires in the lead may not correspond with the coloured markings identifying the terminals in your plug, proceed as follows:
 Connect Green & Yellow wire to terminal marked **E** or \perp or coloured Green or Green & Yellow.
 Connect Brown wire to terminal marked **L** or coloured Red.
 Connect Blue wire to terminal marked **N** or coloured Black.

If a 13 amp plug (BS 1363) is used it must be fitted with a 13 amp fuse, either in the plug or adaptor or at the distribution board.

If you are in any doubt the electrical supply to your machine, consult a qualified electrician before use.

How to connect an alternative plug:

The wires in this mains lead are coloured in accordance with the following code:

BLUE	NEUTRAL (N)
BROWN	LIVE (L)
GREEN & YELLOW	EARTH (E)

Disposing of the appliance:

When disposing of the appliance please remove the plug by cutting the mains cable as close as possible to the plug body and dispose of it as described above.

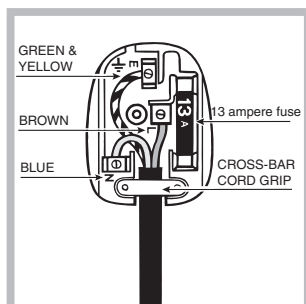

! The washing machine should not be installed in an outdoor environment, not even when the area is sheltered, because it may be very dangerous to leave it exposed to rain and thunderstorms.

! When the washing machine is installed, the mains socket must be within easy reach.

! Do not use extensions or multiple sockets.



! The power supply cable must never be bent or dangerously compressed.

! The power supply cable must only be replaced by an authorised serviceman.

Warning! The company denies all liability if and when these norms are not respected.

The first wash cycle

Once the appliance has been installed, and before you use it for the first time, run a wash cycle with detergent and no laundry, setting the 90°C programme without a pre-wash cycle.

Technical details	
Model	WIB 101
Dimensions	59.5 cm wide 85 cm high 52,5 cm deep
Capacity	from 1 to 5 kg
Electric connections	please refer to the technical data plate fixed to the machine
Water connections	maximum pressure 1 MPa (10 bar) minimum pressure 0.05 MPa (0.5 bar) drum capacity 46 litres
Spin speed	up to 1000 rpm
Control programmes according to EN 60456 directive	programme 3; temperature 60°C; run with a load of 5 kg.
 	<p>This appliance is compliant with the following European Community Directives:</p> <ul style="list-style-type: none"> - 89/336/CEE of 03/05/89 (Electromagnetic Compatibility) and subsequent amendments - 2006/95/CE (Low Voltage) - 2002/96/CE

Washing machine description

GB

Control panel

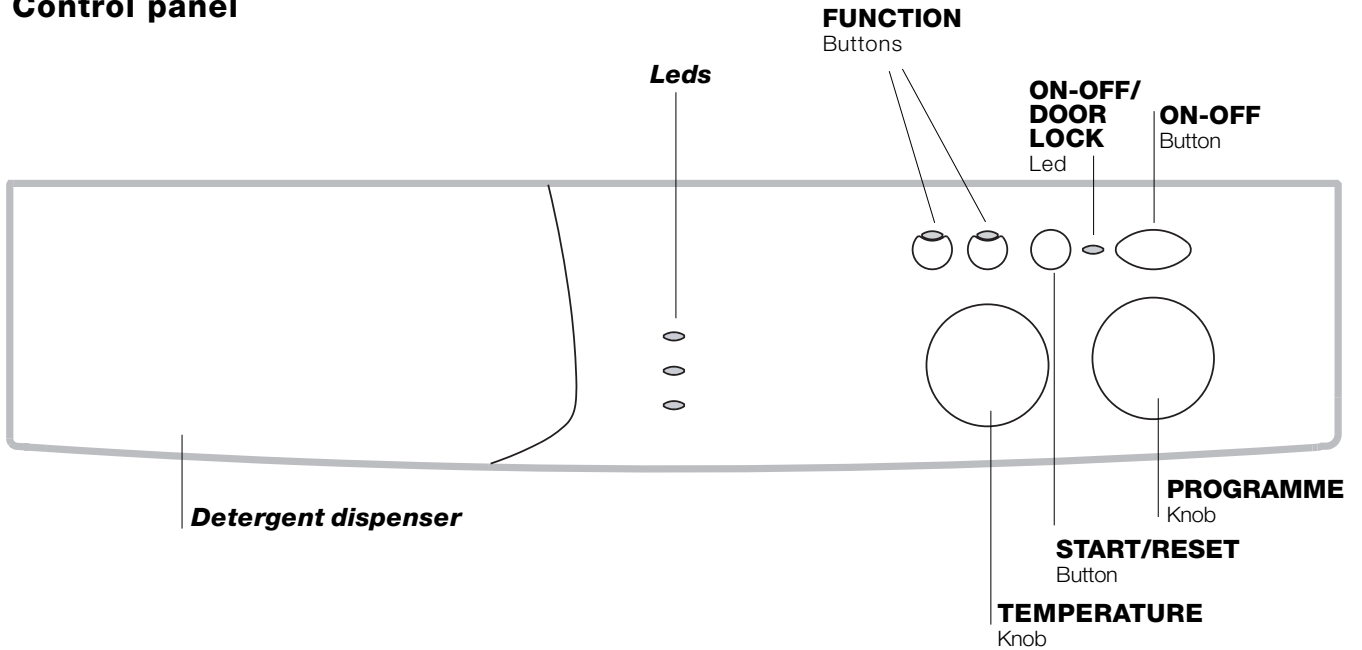

Detergent dispenser: to add detergent and fabric softener (see page 10).

LEDS: to find out which wash cycle phase is under way.

FUNCTION buttons: to select the functions available. The button corresponding to the function selected will remain on.

TEMPERATURE knob: to set the temperature or the cold wash cycle (see page 9).

START/RESET button: to start the programmes or cancel any incorrect settings.

ON-OFF/DOOR LOCK Led: to find out whether the washing machine is on and if the appliance door can be opened (see page 7).

ON/OFF button: to turn the washing machine on and off.

PROGRAMME knob: to select the wash programmes. The knob stays still during the cycle.

Leds

The LEDS provide important information.
This is what they can tell you:

Cycle phase under way:

During the wash cycle, the LEDs gradually illuminate on to indicate the cycle phase under way:

 Wash

 Rinse

 Spin cycle

Note: during draining, the LED corresponding to the Spin cycle phase will be turned on.

Function buttons

The FUNCTION BUTTONS also act like LEDS.
When a function is selected, the corresponding button is illuminated.

If the function selected is incompatible with the programme set, the button will flash and the function will not be enabled.

If you set a function that is incompatible with another function you selected previously, only the last one selected will be enabled.

ON-OFF/DOOR LOCK led



If this LED is on, the appliance door is locked to prevent it from being opened accidentally; to avoid any damages, wait for the LED to flash before you open the appliance door.

! The rapid flashing of the ON-OFF/DOOR LOCK Led together with the flashing of at least one other LED indicates there is an abnormality (see page 13).





Starting and Programmes

GB

Briefly: starting a programme

- Switch the washing machine on by pressing button . All the LEDs will light up for a few seconds and the ON-OFF/DOOR LOCK Led will begin to flash.
- Load your laundry into the washing machine and shut the appliance door.
- Set the PROGRAMME knob to the programme required.
- Set the wash temperature (see page 9).
- Add the detergent and any fabric softener (see page 10).
- Start the programme by pressing the START/RESET button.
To cancel it, keep the START/RESET button pressed for at least 2 seconds.
- When the programme is finished, the ON-OFF/DOOR LOCK Led will flash to indicate that the appliance door can be opened. Take out your laundry and leave the appliance door ajar to allow the drum to dry thoroughly. Turn the washing machine off by pressing button .

Programme table

Type of fabric and degree of soil	Programmes	Wash temperat.	Detergent		Fabric softener	Cycle length (minutes)	Description of wash cycle
			Pre-wash	Wash			
Cotton							
Extremely soiled whites (sheets, tablecloths, etc.)	1	90°C	•	•	•	167	Pre-wash, wash cycle, rinse cycles, intermediate and final spin cycles
Extremely soiled whites (sheets, tablecloths, etc.)	2	90°C		•	•	152	Wash cycle, rinse cycles, intermediate and final spin cycles
Heavily soiled whites and fast colours	3	60°C		•	•	158	Wash cycle, rinse cycles, intermediate and final spin cycles
Heavily soiled whites and delicate colours	3	40°C		•	•	143	Wash cycle, rinse cycles, intermediate and final spin cycles
Slightly soiled whites and delicate colours (shirts, jumpers, etc.)	4	40°C		•	•	99	Wash cycle, rinse cycles, intermediate and final spin cycles
Slightly soiled delicate colours	5	30°C		•	•	92	Wash cycle, rinse cycles, intermediate and final spin cycles
Synthetics							
Heavily soiled fast colours (baby linen, etc.)	6	60°C		•	•	80	Wash cycle, rinse cycles, anti-crease or delicate spin cycle
Fast colours (all types of slightly soiled garments)	6	40°C		•	•	71	Wash cycle, rinse cycles, anti-crease or delicate spin cycle
Heavily soiled fast colours (baby linen, etc.)	7	50°C		•	•	75	Wash cycle, rinse cycles, anti-crease or delicate spin cycle
Delicate colours (all types of slightly soiled garments)	8	40°C		•	•	71	Wash cycle, rinse cycles, anti-crease or delicate spin cycle
Delicate colours (all types of slightly soiled garments)	9	30°C		•	•	30	Wash cycle, rinse cycles and delicate spin cycle
Delicates							
Wool	10	40°C		•	•	50	Wash cycle, rinse cycles and delicate spin cycle
Very delicate fabrics (curtains, silk, viscose, etc.)	11	30°C		•	•	52	Wash cycle, rinse cycles, anti-crease or draining cycle
PARTIAL PROGRAMMES							
Rinse					•		Rinse cycles and spin cycle
Light rinse cycle					•		Rinse cycles, anti-crease or draining
Spin cycle							Draining and heavy duty spin cycle
Light spin cycle							Draining and delicate spin cycle
Drain							Draining

Notes

For the anti-crease function: see opposite page. The information contained in the table is purely indicative.

Special programme

Daily (programme 9 for Synthetics) is designed to wash lightly soiled garments in a short amount of time: it only lasts 30 minutes and allows you to save on both time and energy. By setting this programme (9 at 30°C), you can wash different fabrics together (except for woollen and silk items), with a maximum load of 3 kg.

We recommend the use of liquid detergent.

Setting the temperature

Turn the TEMPERATURE knob to set the wash temperature (see Programme table on page 8).
The temperature can be lowered, or even set to a cold wash (❄).





GB

Functions

To enable a function:

1. press the button corresponding to the desired function, according to the table below;
2. the function is enabled when the corresponding button is illuminated.

Note: The rapid flashing of the button indicates that the corresponding function cannot be selected for the programme set.

Function	Effect	Comments	Enabled with programmes:
 Rapid wash	Cuts the duration of the wash cycle by 30%.		1, 2, 3, 4, 5, 6, 7, 8
 Anti crease	This option reduces the amount of creasing on fabrics, making them easier to iron.	When this function is set, programmes 6, 7, 8, 11 and light rinse cycle will end with the laundry left to soak (Anti-crease) and the Rinse cycle phase LED  will flash. - to conclude the cycle, press the START/RESET button; - to run the draining cycle alone, set the knob to the relative symbol  and press the START/RESET button.	6, 7, 8, 11, Delicate Rinse cycle.

Note: to avoid excessive vibrations, before every spin cycle the machine distributes the load in a uniform manner by continuously rotating the drum at a speed which is slightly faster than the normal washing speed.

When, despite repeated attempts, the load is still not evenly distributed, the machine spins at a lower speed than the set frequency.

If the load is excessively unbalanced, the machine attempts to distribute it instead of spinning.

The balancing attempts may extend the total duration of the cycle, up to a maximum of 10 minutes.

Detergents and laundry

GB

Detergent dispenser

Good washing results also depend on the correct dose of detergent: adding too much detergent won't necessarily make for a more efficient wash, and may in fact cause build up on the interior of your appliance and even pollute the environment.



Open up the detergent dispenser and pour in the detergent and fabric softener, as follows.

compartment 1: Detergent for pre-wash (powder)

compartment 2: Detergent for the wash cycle (powder or liquid)

Liquid detergent should only be poured in immediately prior to the wash cycle start.

compartment 3: Additives (fabric softeners, etc.)

The fabric softener should not overflow from the grid.

! Do not use hand wash detergent because it may form too much foam.

Preparing your laundry

- Divide your laundry according to:
 - the type of fabric/the symbol on the label.
 - the colours: separate coloured garments from whites.
- Empty all pockets and check for loose buttons.
- Do not exceed the weight limits stated below, which refer to the weight when dry:
 - Sturdy fabrics: max 5 kg
 - Synthetic fabrics: max 2.5 kg
 - Delicate fabrics: max 2 kg
 - Wool: max 1 kg

How much does your laundry weigh?

- 1 sheet 400-500 g
- 1 pillow case 150-200 g
- 1 tablecloth 400-500 g
- 1 bathrobe 900-1200 g
- 1 towel 150-250 g

Special items

Curtains: fold curtains and place them in a pillow case or mesh bag. Wash them separately without exceeding half the appliance load. Use programme 11 which excludes the spin cycle automatically.

Quilted coats and windbreakers: if they are padded with goose or duck down, they can be machine-washed. Turn the garments inside out and load a maximum of 2-3 kg, repeating the rinse cycle once or twice and using the delicate spin cycle.

Wool: for best results, use a specific detergent, taking care not to exceed a load of 1 kg.

! The washing machine was designed and built in compliance with the applicable international safety regulations. The following information is provided for your safety and should consequently be read carefully.

General safety

- This appliance has been designed for non-professional, household use and its functions must not be changed.
- This washing machine should only be used by adults and in accordance with the instructions provided in this manual.
- Never touch the washing machine when barefoot or with wet or damp hands or feet.
- Do not pull on the power supply cable to unplug the appliance from the electricity socket. Pull the plug out yourself.
- Do not open the detergent dispenser while the appliance is in operation.
- Do not touch the drain water as it could reach very high temperatures.
- Never force the washing machine door: this could damage the safety lock mechanism designed to prevent any accidental openings.
- In the event of a malfunction, do not under any circumstances touch internal parts in order to attempt repairs.
- Always keep children well away from the appliance while in operation.
- The appliance door tends to get quite hot during the wash cycle.
- Should it have to be moved, proceed with the help of two or three people and handle it with the utmost care. Never try to do this alone, because the appliance is very heavy.
- Before loading your laundry into the washing machine, make sure the drum is empty.

Disposal

- Disposing of the packaging material: observe local regulations, so the packaging can be re-used.
- The European Directive 2002/96/EC on Waste Electrical and Electronic Equipment, requires that old household electrical appliances must not be disposed of in the normal unsorted municipal waste stream. Old appliances must be collected separately in order to optimise the recovery and recycling of the materials they contain and reduce the impact on human health and the environment.

The crossed out "wheeled bin" symbol on the product reminds you of your obligation, that when you dispose of the appliance it must be separately collected.

Consumers should contact their local authority or retailer for information concerning the correct disposal of their old appliance.

Saving energy and respecting the environment

Environmentally-friendly technology

If you only see a little water through your appliance door, this is because thanks to the latest Indesit technology, your washing machine only needs less than half the amount of water to get the best results: an objective reached to respect the environment.

Saving on detergent, water, energy and time

- To avoid wasting resources, the washing machine should be used with a full load. A full load instead of two half loads allows you to save up to 50% on energy.
- The pre-wash cycle is only necessary on extremely soiled garments. Avoiding it will save on detergent, time, water and between 5 and 15% energy.
- Treating stains with a stain remover or leaving them to soak before washing will cut down the need to wash them at high temperatures. A programme at 60°C instead of 90°C or one at 40°C instead of 60°C will save up to 50% on energy.
- Use the correct quantity of detergent depending on the water hardness, how soiled the garments are and the amount of laundry you have, to avoid wastage and to protect the environment: despite being biodegradable, detergents do contain ingredients that alter the natural balance of the environment. In addition, avoid using fabric softener as much as possible.
- If you use your washing machine from late in the afternoon until the early hours of the morning, you will help reduce the electricity board's peak load.
- If your laundry has to be dried in a tumble dryer, select a high spin speed. Having the least water possible in your laundry will save you time and energy in the drying process.

Care and maintenance

GB

Cutting off the water or electricity supply

- Turn off the water tap after every wash. This will limit the wear of your appliance's water system and also prevent leaks.
- Unplug your appliance when cleaning it and during all maintenance operations.

Cleaning your appliance

The exterior and rubber parts of your appliance can be cleaned with a soft cloth soaked in lukewarm soapy water. Do not use solvents or abrasives.

Cleaning the detergent dispenser

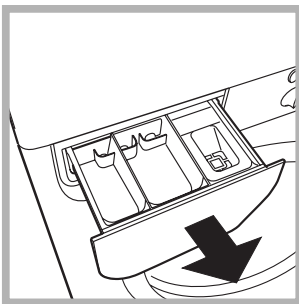

Remove the dispenser by pulling it out (see *figure*). Wash it under running water; this operation should be repeated frequently.

Caring for your appliance door and drum

- Always leave the appliance door ajar to prevent unpleasant odours from forming.

Cleaning the pump

The washing machine is fitted with a self-cleaning pump that does not require any maintenance. Sometimes, small items (such as coins or buttons) may fall into the pre-chamber that protects the pump, situated in the lower part of the same.

! Make sure the wash cycle has ended and unplug the appliance.

To access the pre-chamber:

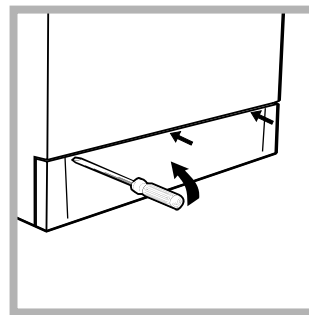

1. using a screwdriver, remove the cover panel on the lower front of the washing machine (see *figure*);

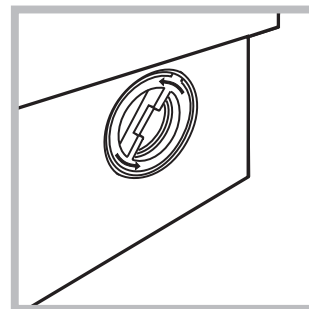

2. unscrew the lid rotating it anti-clockwise (see *figure*): a little water may trickle out. This is perfectly normal;

3. clean the interior thoroughly;
4. screw the lid back on;
5. reposition the panel, making sure the hooks are securely in place before you push it onto the appliance.

Checking the water inlet hose

Check the water inlet hose at least once a year. If you see any cracks, replace it immediately: during the wash cycles, water pressure is very strong and a cracked hose could easily split open.

! Never use hoses that have already been used.

Your washing machine could fail to work. Before calling for Assistance (*see page 14*), make sure the problem can't easily be solved by consulting the following list.

Problem

Possible causes/Solution:

The washing machine won't start.

- The appliance is not plugged into the socket, or not enough to make contact.
- There has been a power failure.

The wash cycle won't start.

- The appliance door is not shut properly.
- The  button has not been pressed.
- The START/RESET button has not been pressed.
- The water tap is not turned on.

The washing machine fails to load water.

- The water inlet hose is not connected to the tap.
- The hose is bent.
- The water tap is not turned on.
- There is a water shortage.
- The water pressure is insufficient.
- The START/RESET button has not been pressed.

The washing machine continuously loads and unloads water.

- The drain hose is not fitted between 65 and 100 cm from the floor (*see page 3*).
- The free end of the hose is underwater (*see page 3*).
- The wall drainage system doesn't have a breather pipe.

If the problem persists even after these checks, turn off the water tap, switch the appliance off and call for Assistance. If the dwelling is on one of the upper floors of a building, there may be drain trap problems causing the washing machine to load and unload water continuously. In order to avoid such an inconvenience, special anti-drain trap valves are available in shops.

The washing machine does not drain or spin.

- The programme does not foresee the draining: some programmes require enabling the draining manually (*see page 8*).
- The "Rinse Hold" function is enabled: to complete the programme, press the START/RESET button (*see page 9*).
- The drain hose is bent (*see page 3*).
- The drain duct is clogged.

The washing machine vibrates too much during the spin cycle.

- The drum was not unblocked correctly during installation (*see page 2*).
- The washing machine is not level (*see page 2*).
- The washing machine is closed in between furniture cabinets and the wall (*see page 2*).

The washing machine leaks.

- The water inlet hose is not screwed on correctly (*see page 2*).
- The detergent dispenser is obstructed (to clean it, *see page 12*).
- The drain hose is not secured properly (*see page 3*).

The ON-OFF/DOOR LOCK Led flashes rapidly at the same time as at least one other LED.

- Switch off the machine and unplug the appliance; wait for approximately 1 minute then switch it on again. If the problem persists, contact Assistance.

There is too much foam.

- The detergent is not suitable for machine washing (it should bear the definition "for washing machines" or "hand and machine wash", or the like).
- You used too much detergent.

Service

GB

Before calling for Assistance:

- Check whether you can solve the problem on your own (*see page 13*);
- Restart the programme to check whether the problem has been solved;
- If this is not the case, contact an authorised Technical Service Centre on the telephone number provided on the guarantee certificate.

! Always request the assistance of authorised servicemen.

Notify the operator of:

- the type of problem;
- the appliance model (Mod.);
- the serial number (S/N).

This information can be found on the data plate situated on the rear of the washing machine.

12 Months Parts and Labour Guarantee

Your appliance has the benefit of our manufacturer's guarantee, which covers the cost of breakdown repairs for twelve months from the date of purchase.

This gives you the reassurance that if, within that time, your appliance is proven to be defective because of either workmanship or materials, we will, at our discretion, either repair or replace the appliance at no cost to you.

This guarantee is subject to the following conditions:

- The appliance has been installed and operated correctly and in accordance with our operating and maintenance instructions.
- The appliance is used only on the electricity or gas supply printed on the rating plate.
- The appliance has been used for normal domestic purposes only.
- The appliance has not been altered, serviced, maintained, dismantled, or otherwise interfered with by any person not authorised by us.
- Any repair work must be undertaken by us or our appointed agent.
- Any parts removed during repair work or any appliance that is replaced become our property.
- The appliance is used in the United Kingdom or Republic of Ireland.

The guarantee does not cover:

- Damage resulting from transportation, improper use, neglect or interference or as a result of improper installation.
- Replacement of any consumable item or accessory . These include but are not limited to: plugs, cables, batteries, light bulbs, fluorescent tubes and starters, covers and filters.
- Replacement of any removable parts made of glass or plastic.

THIS GUARANTEE WILL NOT APPLY IF THE APPLIANCE HAS BEEN USED IN COMMERCIAL OR NON-DOMESTIC PREMISES.

Extended Guarantees

We offer a selection of repair protection plans that enable you to fully cover yourself against the expense of repair bills for the life of your policy. To find the ideal plan for you please call our advice line on

08709 088 088 (ROI 01 230 0233).

Free Helpdesk Service

We have a dedicated team who can provide free advice and assistance with your appliance if you experience any technical difficulties within the first 90 days of ownership. Simply call our Indesit Service Hotline on **08709 066 066 (ROI 0818 313 413)** for telephone assistance, or, where necessary, to arrange for an engineer to call.

After Sales Service

No one is better placed to care for your Indesit appliance during the course of its working life than us - the manufacturer.

Essential Contact Information

Indesit Service

We are the largest service team in Europe offering you access to 400 skilled telephone advisors and 1100 fully qualified engineers on call to ensure you receive fast, reliable, local service.

UK: 08709 066 066

Republic of Ireland: 0818 313 413

www.indesitservice.co.uk

Please note: Our advisors will require the following information:

Model number:

Serial number:

Parts and Accessories

We supply a full range of genuine replacement parts as well as accessory products that protect and hygienically clean your appliance to keep it looking good and functioning efficiently throughout its life.

UK: 08709 077 077

Republic of Ireland: 0818 313 413

www.indesitservice.co.uk

Indesit Company UK Ltd. Morley Way, Peterborough, PE2 9JB

Indesit Company Unit 49 Airways Industrial Estate, Dublin 17



Recycling & Disposal Information

As part of Indesit's continued commitment to helping the environment, Indesit reserves the right to use quality, recycled components to keep down customer costs and minimise material wastage.

Please dispose of packaging and old appliances carefully. To minimise the risk of injury to children, remove the door, plug and cut the mains cable off flush with the appliance. Dispose of these parts separately to ensure that the appliance can no longer be plugged into a mains socket, and the door cannot be locked shut.